

Smooth Strand

NATURAL WALLS AND CEILINGS
www.anutone.com/strand.htm



Smooth Strand

Key Attributes

The unique random twirls of fibre construction and textured surface finish sets Strand apart in choice of ceilings. A natural 'breathing' panel with the timeless appeal of fibres sharply contrasts the smooth surfaces of glazing, drywalls and stone floors. Strand is woodwool board and comes in four variants: Strand Plus, Strand, Strand SS and Strandec. See table elsewhere for comparative features

Aesthetics

Strand boasts of textured surface and edge treatment, important for installed aesthetics. For ceilings, Strand has edge profiles in Square, Reverse Steppe, Steppe, Steppe Chamfer. For panellings, edge profiles consist of Radius, Chamfer, Tongue-Groove & H-Spline groove.



Typical Applications

Strand Plus and Strand is used exposed for ceilings and walls in offices, schools, cinema, auditoriums, studios etc.

Visual Variants

The visual variants for Strand Plus and Strand are realised when the panels are factory or insitu *fine-mist* spray painted in a range of bold colours or pastel shades or contrasts.

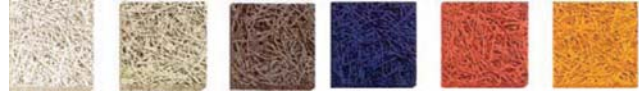

Design Considerations

Strand Square edge must never be butt jointed. Chamfer long edges with staggered short edges work the best. Options include panels with Square or Chamfer edge, staggered and separated by a 4-6 mm gap to create natural grooves. Strand must not be installed at pedestrian height unless the surface is covered with a finishing materials such as Spun fabrics system or SPH perped surfaces.

Features

Density & dimensions - see comparative table elsewhere Strand Plus, Strand and Strandec conforms to EN 13168 2001, the Euro norm for factory-made woodwool cement boards.

Accessibility

Strand in Skelet T-system makes it modular and dismantable for plenum access to services in the ceiling void. Strand installed on Strut C-system requires unfastening and refastening of fasteners.

Environmental Impact

Strand is eco-friendly and wins 15 LEED points, a green initiative by Anutone®.

Framework

- Skelet T-system for ceilings - exposed suspension
- Skelet C-system for ceilings, panellings, partitions - concealed suspension
- Skelet F-Spline for panellings - fastener-less, quick installation

Tech Performance

- Non-combustibility – Mass loss 53% @ 750 °C - ISO 1182
- Ignitibility – 'P' - BS 476 Part 5
- Fire Propagation Index – 5.17 - BS 476 Part 6
- Surface Spread – Class I - BS 476 Part 7
- Specific Optical Density of Smoke – Flaming Exposure 26.28 D_m (Corr) - ASTM E662
- Thermal Conductivity – 0.08 Wm/k - IS 3346

Duolay Matrix

Strand Plus and Strand, thickness 20mm onwards, now come with Anutone's latest Duolay matrix technology. Duolay is a research-engineered pioneering innovation from Anutone that is the most efficient and optimal utilisation of resources.

The panel base consists of wide fibre whereas panel surface consists of superfine fibre for Strand Plus and fine for Strand.

This results in:

- enhanced aesthetics - fibre preservation
- greater strength - wide fibre base support
- better acoustics - variable sound absorption
- cost-savings - why pay for full fine fibre

Logistics

Thk (mm)	Nos./carton	Carton wt (kgs)	Carton size (mm)
25	06	47	1226L x 616W x 175H
38	04	56	
50	03	47	

Logistics info for other thickness on request

Economics

Strand 25mm Chamfer long edges on Strut C-system is techno-commercially economical for the lifecycle cost of the product and the system.

Warranty

10 years limited warranty on the assembled system when installed to Anutone's specifications.

(!Strand was formerly known as Natural SoundSmooth or NSS, SoundSmooth, Smooth. Due to legacy the Strand brand will transit through 2010/2011 and co-exist with the previous names.)

Site Considerations

Strand must be stored on a flat surface and if panels come in contact with water accidentally, they must be air-dried prior to installation. Installation surfaces must be dry and level.

Acoustical Parameters

Sound Absorption Coefficient as per ISO 354

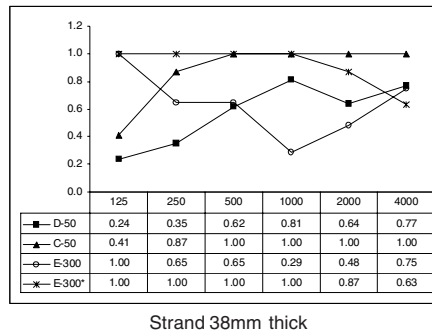
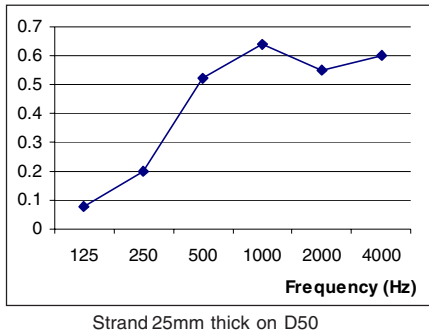

NOTE - Anutone has the capability, expertise and own infrastructure to perform custom acoustics tests for given architectural design as per ISO 354 at its Scans lab at Bengaluru and provide acoustic values of Strand specific to installations.

Installation Guidelines

Ceiling (E300 mounting) – Scope - Design, Supply, Build of Strand, as per approved drawings and specifications, by Anutone Acoustics Limited, an ISO 9001 2008 and ISO 14001 2004 company. **Framework** - Skelet U15-System, consisting of Main and Cross Tees interlocked at 600 mm centres to create a 600x1200mm grid. **Acoustical panels** - Size 595x1195 mm; Thickness 25 mm; Edge profile - Steppe.

Panelling (C10 mounting) – Scope - Design, Supply, Build of Strand, as per approved drawings and specifications, by Anutone Acoustics Limited, an ISO 9001 2000 and ISO 14001 2004 company. **Framework** - Strut C-System, consisting of CC10 Channels fixed at 600mm centres. **Acoustical infill** - Synth PF 10x10 friction-fitted between the Strut Profiles. **Acoustical panels** - Size 600x1200mm; Edge detail - Long edges chamfer and kerfed for H-Spline; Thickness 38 mm installed on Strut C-system with H-Spline. **Joints and finish** - Chamfer long edges, staggered short edges, butt-joined. Caution! No Seam or plaster is applied between the joints.

Installation Drawings

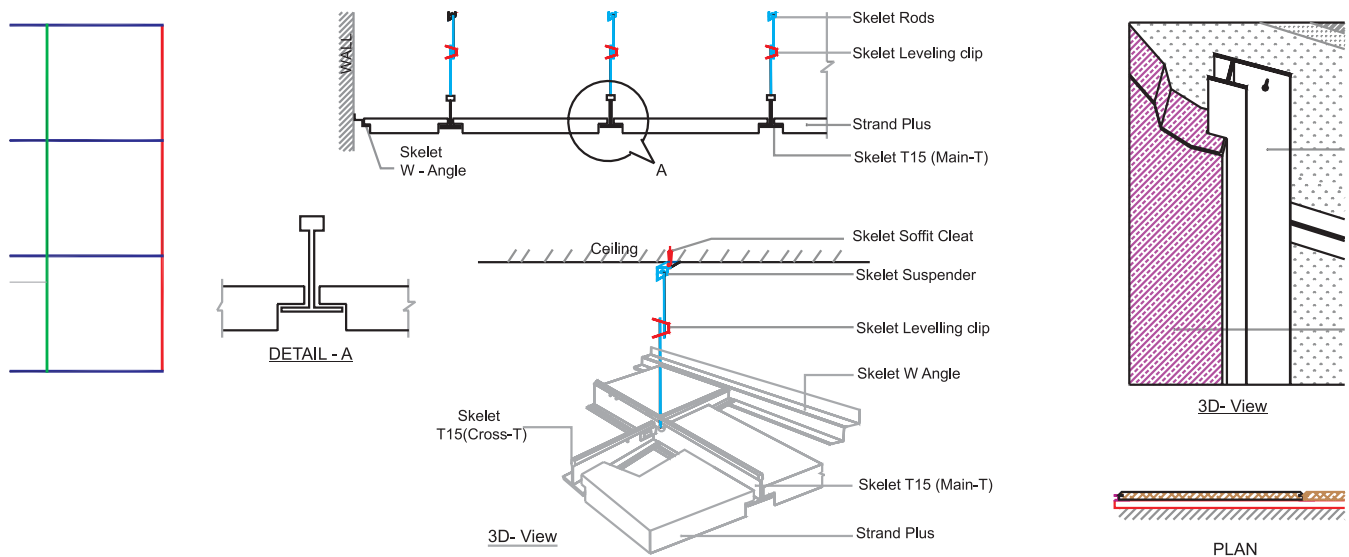



Custom Methodology

The installation of Strand can be custom-designed to suit specific or special project requirements. The methodology includes the entire value-chain of site evaluation, criteria definition, design optimisation, system specs, systems engineering & integration, project management, testing & site validation by Anutone. A service fee is applicable.

Ordering Information

Interior & Installation application, Surface finish, Dimensions, Edge, Painting, Framework, Hardware, Infill, Packing.

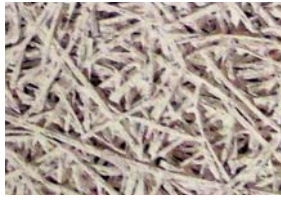
Strand Variants

Brand	Strand Plus	Strand	Strand SS	Strandec
				
Fibre	Superfine	Fine	Medium	Wide
Matrix	Duolay	Duolay		
Cement	Magnesite	Magnesite	Magnesite	Grey
Application	Interiors	Interiors	Interiors	Exteriors
Function	Acoustics	Acoustics	Acoustics	Thermal
Install	Premium	Performance	Budget	Structural
Compliant	Euro	Euro	BIS	Euro
Density	400	400, 600, 800	400	500
Thickness	25, 38, 50	10, 15, 20, 25, 38, 50	15, 20, 25	25, 38, 50
Dimensions	600x1200/2400	600x1200/2400	600x1200	600x1200/2400

Specials

Strand Plus 1200 mm width and lengths of 1200/2400 and upto 3600mm in association with Tectum USA



anutone[®]
makes you feel good[™]

ANUTONE WALLS & CEILINGS

a division of Anutone Acoustics Limited

231, 7th Cross, Indiranagar 1st Stage, Bengaluru 560 038, India
Phone +9180 2520 3114 Fax +9180 2520 3115 info@anutone.com

MUMBAI

+91222 2643 9732

DELHI

+9111 2437 8061

CHENNAI

+9144 4305 4935

www.anutone.com



Anutone is member of

